



General Data

Type reference	KRJSW_2USB_C_5V
Description	Double USB charger 24V/5V 2x 3.0 A USB-C
Approvals	CE, UKCA
Degree of protection	IP20 (in the front); IP10 (on the rear)
Connection type	rear: spring-load terminal 0.2 - 2.5 mm ² front: 2x USB type C
Max. storage temperature	-40°C ... 80°C
Max. operating temperature	-40°C ... 70°C *1)
Mechanical life	10,000 mating cycles for USB C
Material	PA

Technical data

Operational voltage	15 - 31.2 V DC
Output voltage	4.75 - 5.25 V DC
Max. output current	2x 3.0 A *1)
Weight	approx. 28 g

General data

Mounting aperture	30.5mm
Stripping length	10 mm
Panel thickness	2.0...12.0 mm
Mounting depth	73.0 mm
Tightening torque (mounting nut)	1.5 ... 2.2 Nm

Note

DUAL USB CHARGER 24V/5V USB C 2x 3.0 A

For charging USB devices in industrial sectors and in public transport

- Port A USB C maximum output current 3.0 A *1)
- Port B USB C maximum output current 3.0 A *1)
- Battery charging specification (BC1.2), divider mode, 1.2 V/1.2 V mode
- USB type C 5V@3A DFP mode



- Apple MFI R33 certification test (USB-C)

Standards: EN 50155*, EN 61373 class 1B*, EN 60077-1, -2*, EN 45545-2*, EN 60068-2*, EN-50121-3-2*, IEC 61000-6-3/4*, EBA EMV06*; (* relevant parts)

Attention:

The maximum available power depends on the installation situation, the ambient temperature and the quality of the USB charging cable being used. The charging jack has cooling slots allowing a convection. They must be aligned vertically to ensure optimal performance.

Assignment spring terminal (scope of delivery):

(+): U_{IN+} = 15 - 31.2V

(-): U_{IN-} = 0V (GND)

Cable cross section AWG min/max: 30 AWG / 12 AWG

Cable cross section rigid/flexible min/max.: 0.2 mm² / 2.5 mm²

Tool:

Screwdriver 3.5 x 0.5 mm

Protection features:

- Current limitation of the output current for each USB port with short-circuit protection, undervoltage and overvoltage protection
- Thermal overload protection (deactivation of the outputs with automatic restart when reaching an uncritical working temperature)

*1) Temperature monitoring on the USB jack:

If installed in places without air circulation and charging with cables that are not specified for the maximum possible currents, high temperatures can occur at the USB jack. To protect the user, this is continuously thermally monitored. If the temperature becomes too high, the charging process will be interrupted until the temperature falls below a non-critical level. The restart is done automatically.

Data Sheet KRJSW_2USB_C_5V / KRJM_2USB_C_5V (Art. 615400803)

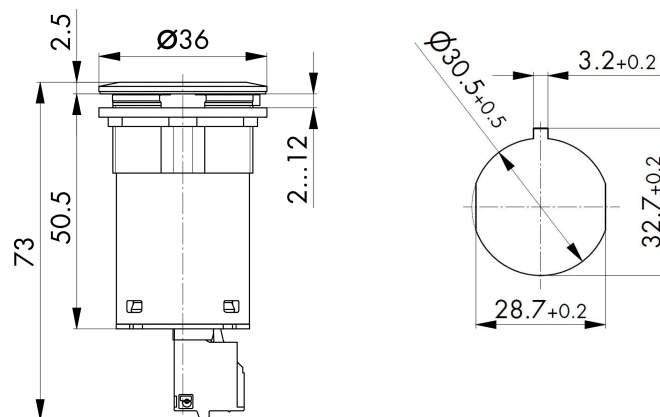

[Bild exemplarisch]



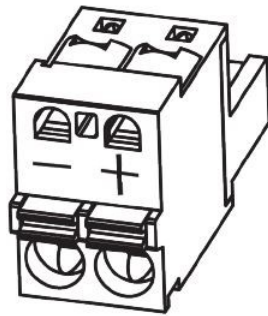
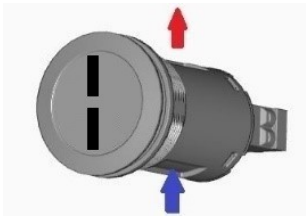

sample picture

